

NOTES:

1. SEE TABLES 40.350.030-3.
2. FEATURES WITHIN CORE ROAD AND FLEX ZONE ARE SUBJECT TO CCC 40.350.030(B)(3) AND TABLE CCC 40.350.030-2.
3. STORMWATER LOW IMPACT DEVELOPMENT (LID) FEATURES IN THE RIGHT-OF-WAY ARE SUBJECT TO CCC 40.350.030(B)(3) AND TABLE CCC 40.350.030-2.

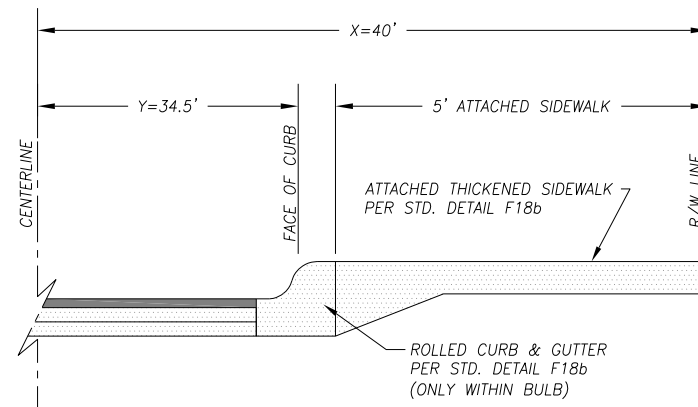
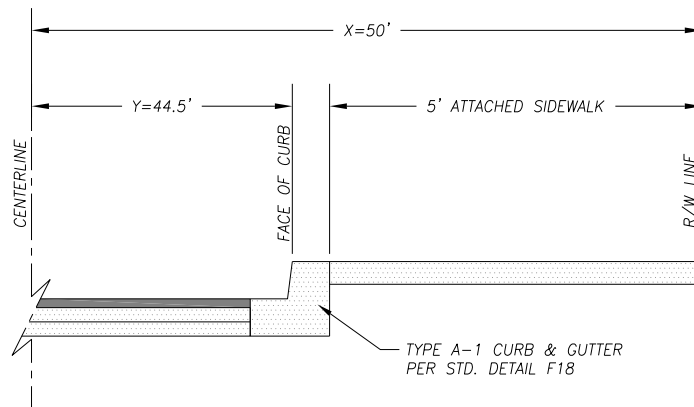

BULB DIMENSIONS

N.T.S.



Department of  
Public Works  
**CLARK COUNTY**  
WASHINGTON  
proud part, promising future

URBAN CUL-DE-SAC

*Peter Capen*  
COUNTY ENGINEER

APPROVED

09/18/13  
DATE

DRAWING  
23

DESIGNED  
DRAWN  
DATE 09/18/13