

SECTION A-A

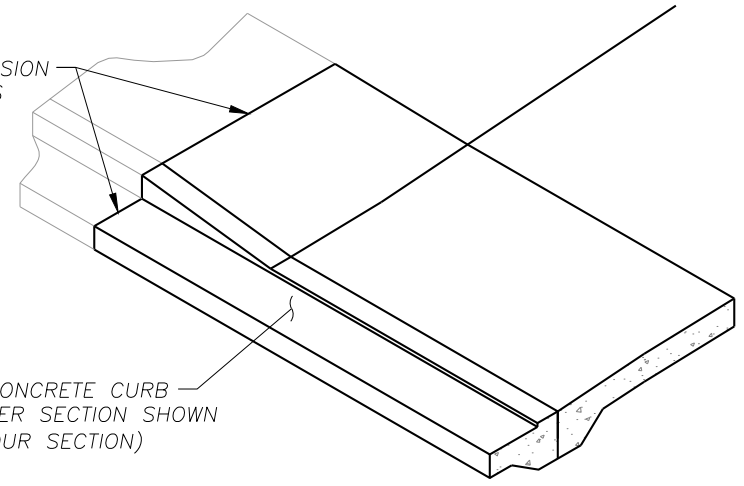

HALF ISOMETRIC

NOTES:

1. CONCRETE SHALL BE CLASS 3000 MIN.
2. CURB TO BE BRUSHED FINISHED. ALL EXISTING EDGES SHALL BE SAWCUT.
3. 1/2" VERTICAL LIP ACROSS APPROACH.
4. SUBGRADE SHALL BE COMPACTED TO 95% MAX DRY DENSITY.
5. MIN. 3" DEPTH CSBC, COMPACTED TO 95% OF MAX. DRY DENSITY.
6. SEE STD. DETAIL F31 FOR CONCRETE JOINTS.

NO.	REVISIONS	DATE	BY

DWG: F18d.DWG



Department of
Public Works
CLARK COUNTY
WASHINGTON
proud past, promising future

CONCRETE DRIVEWAY CUT DETAIL

STANDARD
F18d
DETAIL

APPROVED
[Signature]
COUNTY ENGINEER

DESIGNED
DRAWN
DATE 01/26/16

01/26/16
DATE