

BIO-FILTER BAGS OR STRAW WATTLES MAY BE USED SHORT TERM W/ UTILITY WORK AND W/ PHASING OF DEVELOPMENT

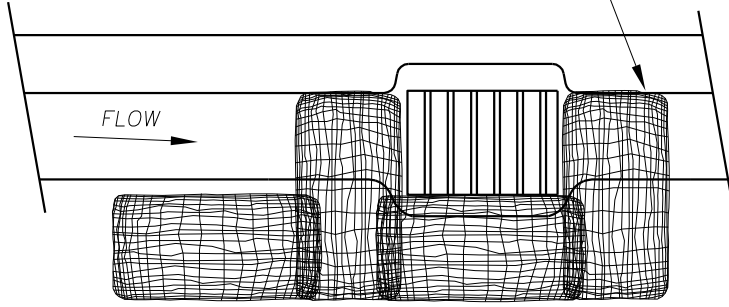

CATCH BASIN

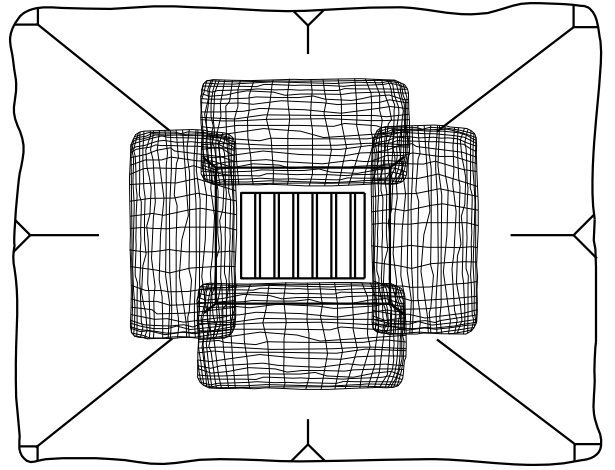

AREA DRAIN

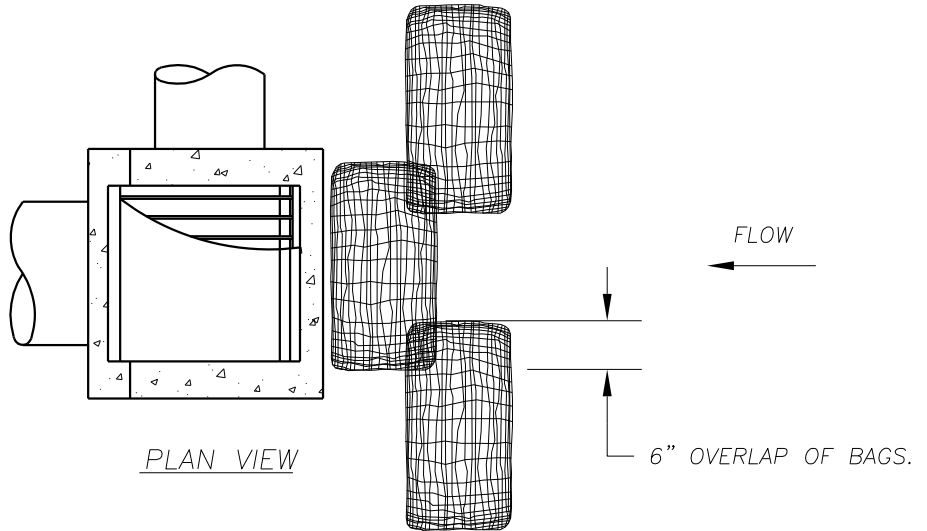

PLAN VIEW

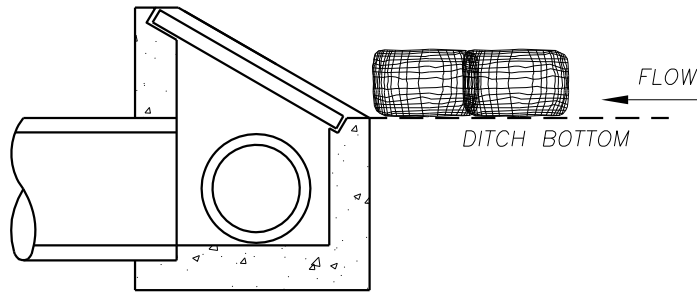

DITCH INLET

NOTES:

1. ADDITIONAL MEASURES MUST BE CONSIDERED DEPENDING ON SOIL TYPE.
2. BIO-FILTER BAGS SHOULD BE STAKED WHERE APPLICABLE USING (2) 1"x2" WOODEN STAKES OR APPROVED EQUAL PER BAG.
3. STRAW WATTLES MUST BE STABILIZED BY ATTACHING WIRE CLIPS TO THE CATCH BASIN PER MANUFACTURERS SPECIFICATIONS.
4. INLET PROTECTION MUST BE REGULARLY INSPECTED BY THE EROSION CONTROL INDIVIDUAL TO INSURE PROPER PLACEMENT/FUNCTION AND MAINTENANCE.
5. SEE INLET PROTECTION NOTES STD. DETAIL E3.

NO.	REVISIONS	DATE	BY

DWG: E3c.DWG



Department of
Public Works
CLARK COUNTY
WASHINGTON
proud past, promising future

INLET PROTECTION TYPE 4
BIO-FILTER BAGS

Peter Capen
COUNTY ENGINEER

APPROVED

5/23/08
DATE

STANDARD
E3c
DETAIL
DESIGNED
DRAWN
DATE 05/23/08