

FOR USE AT POINTS
OF TANGENCY

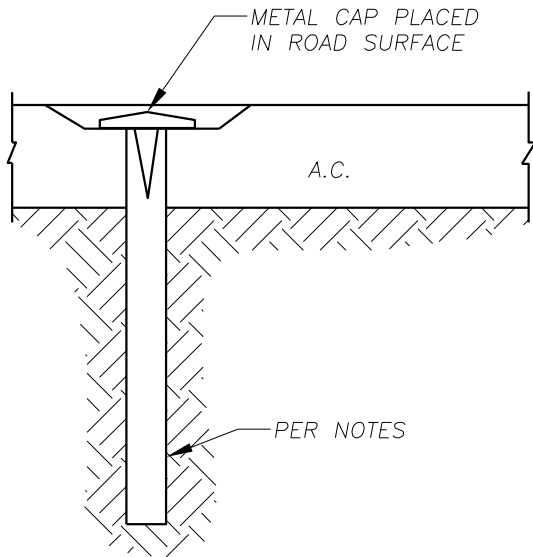

FOR USE IN INTERSECTIONS

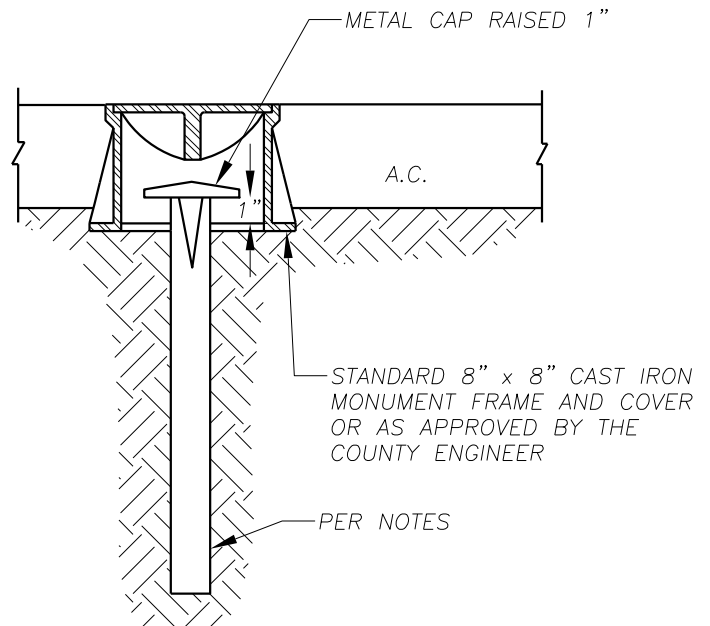

NOTES:

1. ALL MONUMENTS SHALL USE EITHER 5/8" DIAMETER x 30" LONG IRON ROD OR 3/4" DIAMETER x 30" LONG IRON PIPE.
2. ALL MONUMENTS SHALL BE IN ACCORDANCE WITH WAC 196-29-110 AND 332-120-060, AND MEET THE REQUIREMENTS OF THE RCW 58.17.240, 58.09.120 AND 58.09.130.

NO.	REVISIONS	DATE	BY

DWG: F28.DWG



Department of
Public Works
CLARK COUNTY
WASHINGTON
proud past, promising future

CENTERLINE MONUMENTS

Peter Capen
COUNTY ENGINEER

APPROVED

5/23/08
DATE

STANDARD
F28
DETAIL
DESIGNED
DRAWN
DATE 05/23/08