

SEE STANDARD DETAIL F1 FOR CONSTRUCTION NOTES R1-R12. ALL NOTES APPLY UNLESS OTHERWISE NOTED.

LEGEND
 Slope In Either Direction

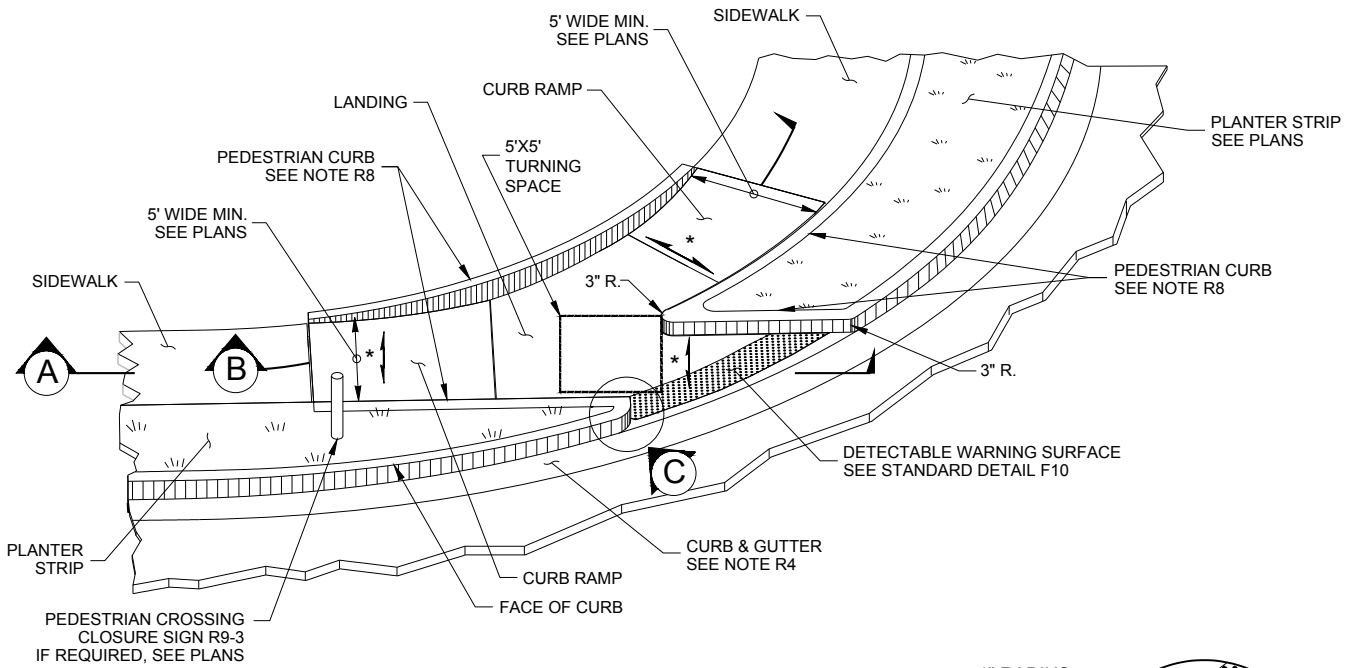

ISOMETRIC VIEW

- * 1.5% OR FLATTER RECOMMENDED FOR DESIGN/FORMWORK (2% MAX)
- ** 7.5% OR FLATTER RECOMMENDED FOR DESIGN/FORMWORK (8.3% MAX)

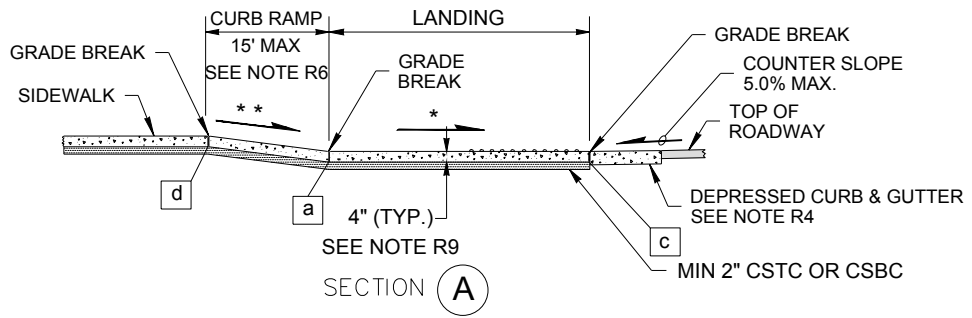
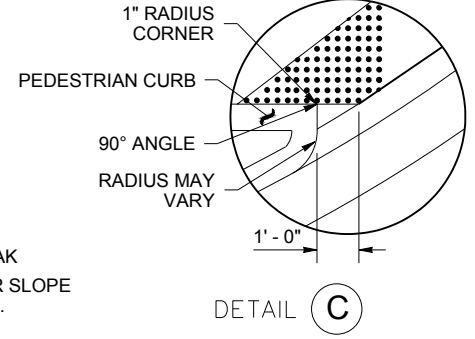

SECTION A

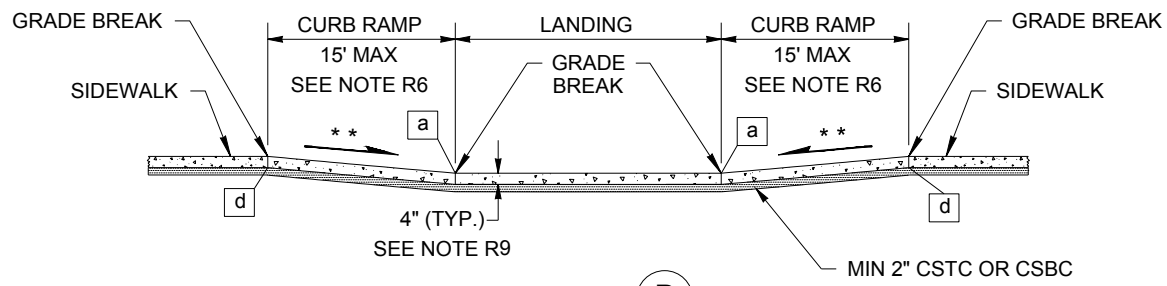

SECTION B

NO.	REVISIONS	DATE	BY
1	REVISE GRADES	5-1-17	BK

DWG: F7.DWG



Department of Public Works
CLARK COUNTY
 WASHINGTON
 proud past, promising future

SINGLE DIRECTION CURB RAMP - TYPE C

[Signature] APPROVED
 COUNTY ENGINEER

01/26/16
 DATE

STANDARD
F7
 DETAIL
 DESIGNED
 DRAWN
 DATE 01/26/16