



ADA Compliance Program

Clark County Sheriff's Office Central Precinct – NE 149th Street

Date: March 6, 2008

Committee Members:

- Wayne Yarnall
- Trenton Hanson
- Jesse Magana
- Bud Van Cleve
- Tim McVicker

	<p>Item # 1</p> <p>Issue: Detectable Warnings</p> <p>Issue:</p> <p>Location: South Parking Lot - Access Aisles</p> <p>Code: Code: IBC- Section 1102 Definitions – Detectable Warnings – A standardized surface feature built in or applied to walking surfaces or other elements to warn visually impaired persons of hazards on a circulation path.</p> <p>Notes: Ramps should be recessed and constructed in the pathway; not extended out into the access aisle</p> <p>See ANSI A117.1-2003 Chapter 406 Curb Ramps – Curb ramps need to be constructed.</p>
	<p>Item # 2</p> <p>Issue: Curb Ramp Obstruction</p> <p>Issue:</p> <p>Location: South Parking Lot</p> <p>Code: ANSI A117.1-2003 – Section 4006.8 Obstructions – Curb ramps shall be located or protected to prevent their obstruction by parked vehicles.</p> <p>Notes: Ramps should be recessed and constructed in the pathway; not extended out into the access aisle</p> <p>See ANSI A117.1-2003 Chapter 406 Curb</p>

Ramps – Curb ramps need to be constructed.

Item # 3

Issue: Ramp Edge Protection

Issue:

Location: South Parking Lot

Code: Edge Protection ANSI – Edge protection complying with Section 405.9.1 or 405.9.2 shall be provided on each side of ramp runs and at each side of ramp landings.

Notes:



Item # 4

Issue: Access Aisle Lines

Issue:

Location: South Parking Lot

Code: ANSI Chapter 5 – Section 502.4.4 Marking – Access aisles shall be marked so as to discourage parking in them.

Notes: Discourage Parking - Recommend re-painting the lines within the access aisles to discourage parking within the aisle area

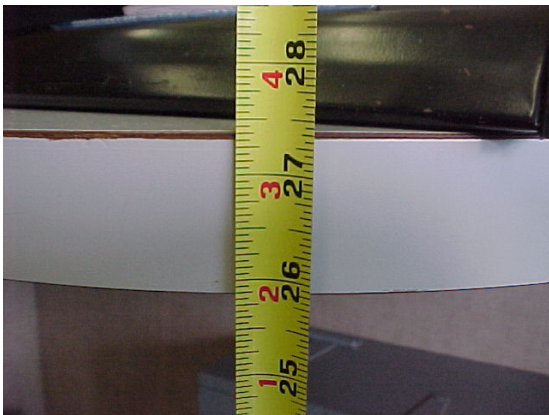

Item # 5

Issue: Height and Clearance

Issue:

Location: Service/Work Counter in Lobby

Code: Code ANSI 306.3.3 Minimum Depth – Where knee clearance is required beneath an element as part of a clear floor space, the knee clearance shall be 11 inches minimum in depth and 9 inches above the floor and 8 inches minimum in depth at 27 inches above the floor.

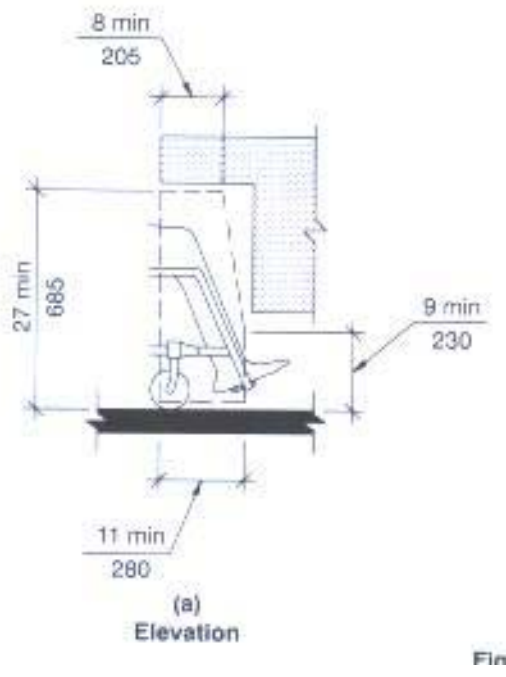
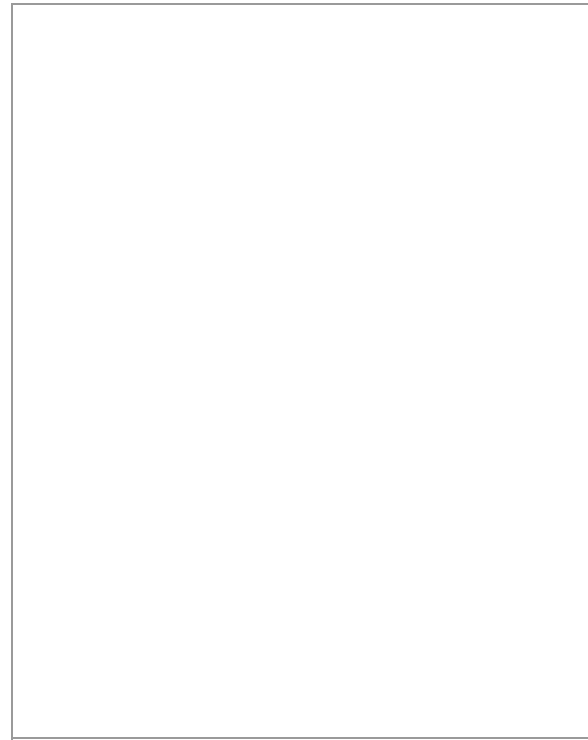

Notes:



Refer to drawing above.

Note:

1. Items under the service counter must be removed to provide wheelchair accessibility to the counter.
2. Display items on top of service counter must be removed when used by an individual for work.



Item # 6
 Issue: Forward Reach
 Issue:
 Location: Accident Report Receptacle – South Entrance
 Code: ANSI 308.2 Forward Reach; 308.2.1 Unobstructed – Where a forward reach is unobstructed, the high forward reach shall be 48 inches maximum and the low forward reach shall be 15 inches minimum above the floor.
 Notes: The top of the receptacle needs to be lowered to a maximum height of 48".

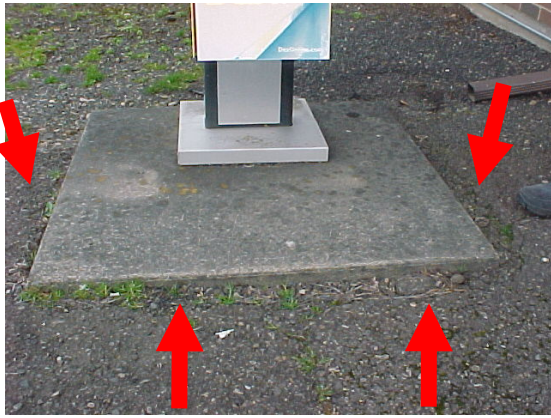

Item # 7

Issue: Walking Surface

Issue:

Location: Public Telephone Southwest Corner of Building

Code: ANSI 302 Floor Surfaces; 302.1 General – Floor surfaces shall be stable, firm and slip resistant.

Changes in Level; 303.2 Vertical - Changes in level of $\frac{1}{4}$ inch maximum in height shall be permitted to be vertical.

Notes: Circulation path/area to the public phone is inaccessible. The surface around the telephone pad needs to be elevated to a uniform grade.