

CLARK COUNTY
STAFF REPORT



DEPARTMENT/DIVISION: General Services/Risk Management

DATE: January 26, 2016

REQUEST: Approve waiver of bid process and authorize repair payment of \$29,247.13 – For emergency repairs to Clark County Chelatchie Prairie Rail Line due to washout.

CHECK ONE: Consent County Manager

BACKGROUND:

Approximately 15 December 2015, a section of the Clark County-Chelatchie Prairie Railroad (CCCP) was undermined due to an extensive culvert washout. The location of the washout was mile post 24 by the tunnel entrance. The culvert washout, which was 40-50 feet deep, undermined 50 linear feet of the rail line which if not immediately repaired would have continued to widen the washout, (especially during the winter months), resulting in more costly repairs and down-time for the railroad. Until repaired, all rail traffic in this vicinity is stopped and the downhill park area is threatened.

This section of the CCCP rail line is critical for rail operations and the ability of the railroad operator to transport goods pursuant to client agreements and contracts. It is Clark County's responsibility to maintain the rail line in a safe and operable condition with regard to threats away from or on the line.

Three vendors were immediately contacted to determine if they were available to make repairs within 24 hours; Belfour Beatty, Railworks, and West Rail Construction Company. Due to the emergent conditions in this incident, the normal bid process for repairs could not be implemented. West Rail Construction Company of Vancouver, WA was the only company available to conduct the work and their services were procured. West Rail Construction immediately initiated repairs to the rail line. Costs for the repairs are \$29,247.13.

COMMUNITY OUTREACH: Not Applicable

BUDGET AND POLICY IMPLICATIONS:

Cost for repairs will be paid from the County's liability fund. It is designed and budgeted for this. Cost is less than the \$50,000 deductible and will not be submitted to the insurer.

Per Clark County Purchasing Policy P-220 – Emergency Purchases Policy – “In an event of an emergency when the public interest or property of the County would suffer material injury or damage by delay, all competitive processes including formal bidding may be waived.” Further, pursuant to RCW 36.32.270 and RCW 39.04.280, for purchases exceeding \$25,000.00, the Clark County Board of County Counselors grants authority to the County Manager to declare an emergency and waive the bidding requirements in conformance with the statutes in the event that the County Manager, after extensive attempts, is unable to confer with the members of the Board of County Counselors in making such a declaration. In addition to the power to declare a county emergency, the County Manager shall have the authority to waive the bid requirements as outlined by the statute in order to remove immediate threats and prevent further loss to the health, safety, property and welfare of the citizens of Clark County. Any actions that go beyond removal of immediate threat, needs the approval of at least three members of the Board of County Counselors.

A brief, concise report regarding the factual circumstances of the emergency along with any and all contracts entered into the emergency authority, shall be presented to the Board of County Counselors for ratification within two (2) weeks of the signing of the contract by the parties for entry in to the official record

Handwritten signature/initials:
MGA
OK
4/1

FISCAL IMPACTS:

(X) No, already budgeted within 5040, Liability Fund.

ADMINISTRATIVE POLICY IMPLICATIONS

No policy implications.

ACTION REQUESTED:

Request the Clark County Board of County Counselors, under the Consent Agenda, approve the waiver of the competitive bid process due to an emergency condition and authority to pay the presented repair cost as audited for \$29,247.13.

BUDGET IMPLICATIONS

YES	NO	
<input checked="" type="checkbox"/>	<input type="checkbox"/>	Action falls within existing budget capacity.
<input type="checkbox"/>	<input type="checkbox"/>	Action falls within existing budget capacity but requires a change of purpose within existing appropriation
<input type="checkbox"/>	<input type="checkbox"/>	Additional budget capacity is necessary and will be requested at the next supplemental. If YES, please complete the budget impact statement. If YES, this action will be referred to the county council with a recommendation from the county manager.

BUDGET DETAILS

Local Fund Dollar Amount	
Grant Fund Dollar Amount	
Account	Liability Fund, 5040
Company Name	

DISTRIBUTION:

Board staff will post all staff reports to The Grid. <http://www.clark.wa.gov/thegrid/>

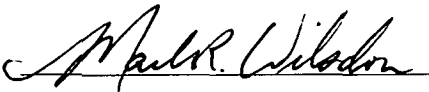

Mark R. Wilsdon

Risk and Management Services



Robert Stevens

Director, General Services

APPROVED: 

CLARK COUNTY, WASHINGTON
BOARD OF COUNTY COUNCILORS

DATE: FEB. 2, 2016

SR# SR 021-16



APPROVED: _____

Mark McCauley, Acting County Manager

DATE: _____

BUDGET IMPACT ATTACHMENT

Part I: Narrative Explanation

I. A – Approve waiver of bid process and authorize repair payment of \$29,247.13 – For emergency repairs to Clark County Chelatchie Prairie Rail Line due to washout.

Part II: Estimated Revenues

Fund #/Title	Current Biennium		Next Biennium		Second Biennium	
	GF	Total	GF	Total	GF	Total
	0	0				
Total	0	0				

II. A – Describe the type of revenue (grant, fees, etc.) NA

Part III: Estimated Expenditures

III. A – Expenditures summed up

Fund #/Title	FTE's	Current Biennium		Next Biennium		Second Biennium	
		GF	Total	GF	Total	GF	Total
5040.000.309.518600.488			29247.13				
Total			29247.13				

III. B – Expenditure by object category

Fund #/Title	Current Biennium		Next Biennium		Second Biennium	
	GF	Total	GF	Total	GF	Total
Salary/Benefits						
Contractual						
Supplies						
Travel						
Other controllables 488		29247.13				
Capital Outlays						
Inter-fund Transfers						
Debt Service						
Total		29247.13				

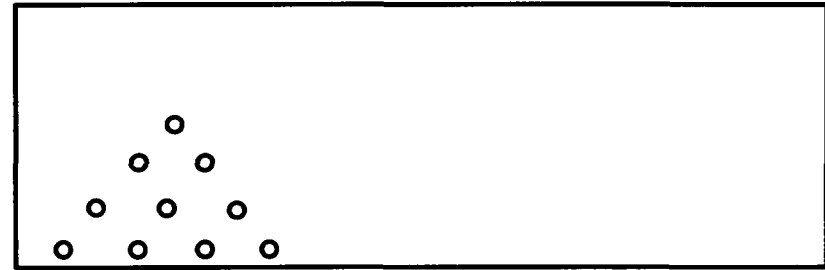

4 Rows 1" holes – 4" spacing

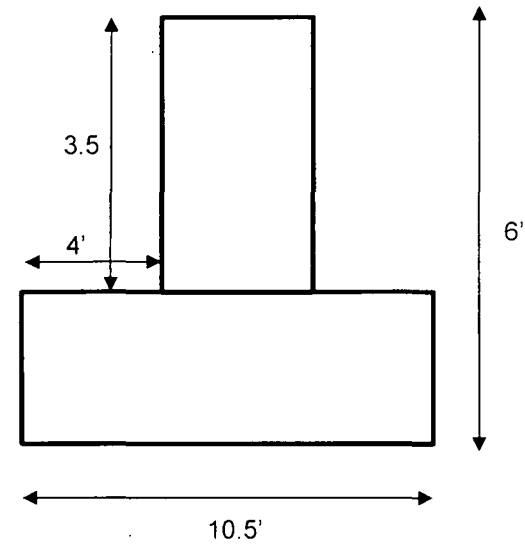
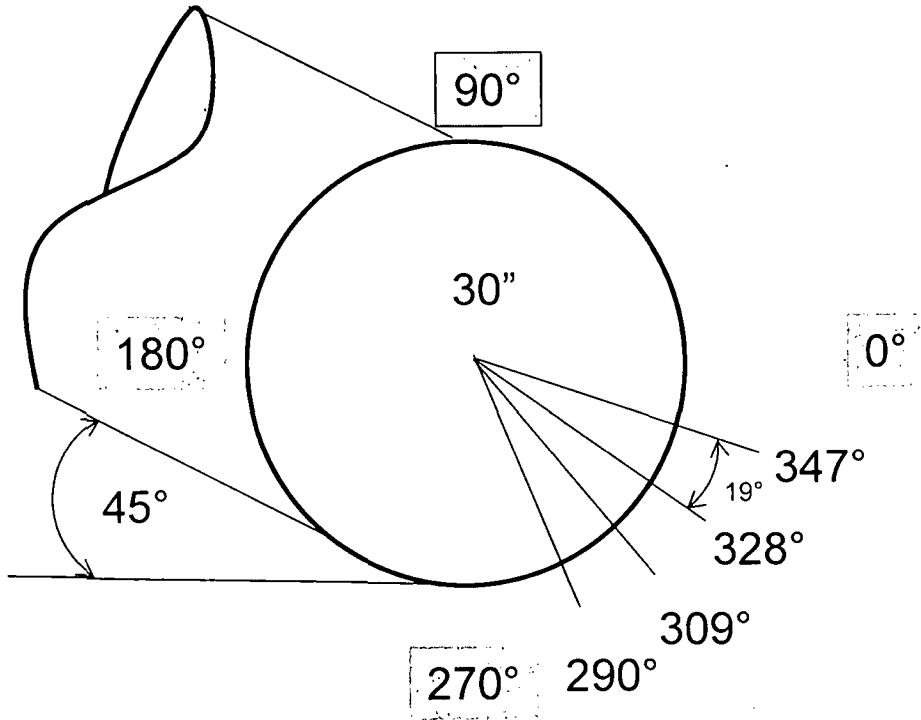

Approved by: _____
NTS – Subject to manufacturing tolerances

Clark County Railroad
Attn: Vern Boley

RESOLUTION NO. 2016-02-01

A RESOLUTION relating to the waiver of bid requirements and retroactively approving the repair of a culvert washout that undermined 40-50 linear feet of Clark County Chelatchie Prairie Rail Line which terminated commerce on the railroad and if not immediately repaired would have resulted in additional damage and material loss to the rail line.

WHEREAS, RCW 36.32.270 allows the County legislative authority to waive the competitive bid requirements, pursuant to RCW 39.04.280, as an emergency exists based upon unforeseen circumstances beyond the control of the municipality that will likely result in a material injury, bodily injury, and additional damage if delayed; and

WHEREAS, a culvert washout discovered on December 15, 2015, measuring 40-50 inches deep by 40-50 feet wide, effectively terminated use of the Clark County Chelatchie Prairie Railroad by the railroad operator in the area of MP 24. If not immediately repaired, the washout most probably would have increased in size, thereby increasing the cost of repair to the County and further delaying return of rail service and transfer of goods; and

WHEREAS, three railroad construction companies were contacted by the County to determine their availability to repair the washout, only one of the companies could immediately initiate the needed repairs; and

WHEREAS, due to the potential for additional harm and bodily risk, the County approved contracts for the repairs; and

WHEREAS, it has been brought to the attention of the Board of County Councilors of Clark County, Washington, that findings and conclusions are required to support the waiver of bids and the immediate approval of repairs, now, therefore,

BE IT ORDERED AND RESOLVED BY THE BOARD OF THE COUNCILORS FOR CLARK COUNTY, STATE OF WASHINGTON that the purchasing and posting requirements of RCW 36.32.245 are hereby waived pursuant to RCW 32.32.270 and RCW 39.04.280 and emergency repairs are authorized. Copies of this resolution shall be filed with the Clark County Auditor.

ADOPTED THIS 2nd DAY OF ~~January~~ February, 2016.

Attest:

Rebecca Jitta
Clerk of the Board

Approved as to form only:

Tony Golik

Prosecuting Attorney

Christopher Horne
Christopher Horne, Chief Civil Deputy

BOARD OF COUNTY COUNCILORS

By: Marc Boldt
Chair, Marc Boldt

By: _____
Councilor Julie Olson

By: _____
Councilor Jeanne E. Stewart

By: _____
Councilor David Madore

By: _____
Councilor Tom Mielke