

TYPE A-1/E-1 CURB - SEE STD. DETAIL F18

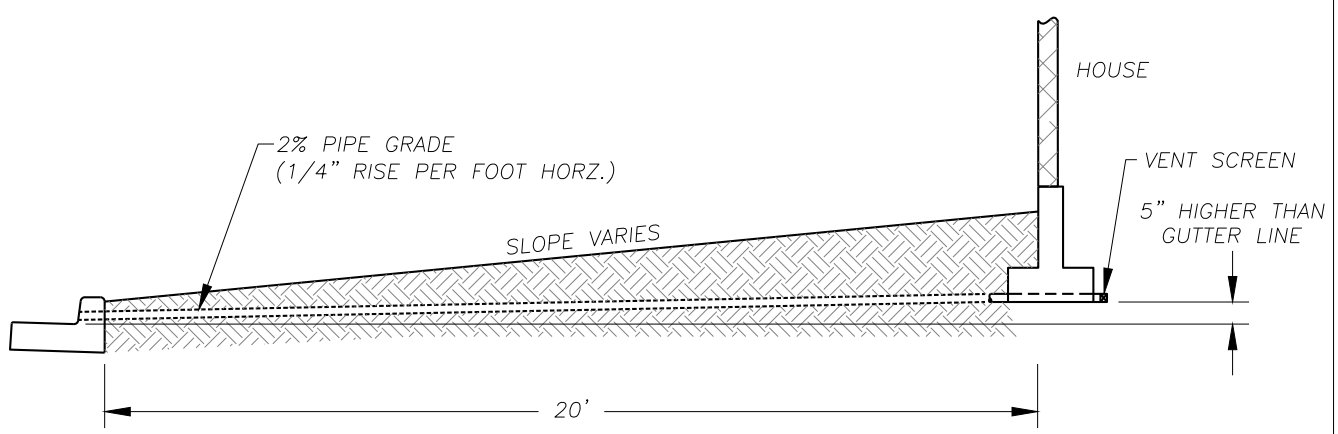
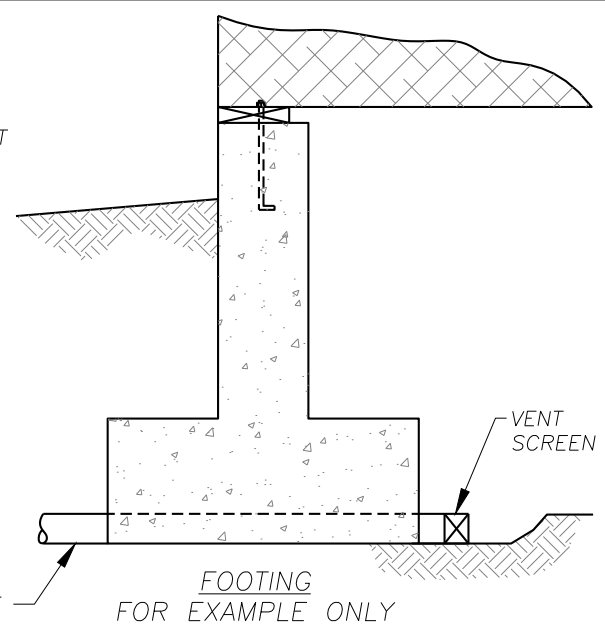

CCC 40.385:

ALL LOTS WITHIN THE URBAN GROWTH AREA MUST BE DESIGNED TO PROVIDE POSITIVE DRAINAGE FROM BOTTOM OF FOOTINGS TO AN APPROVED STORMWATER SYSTEM. POSITIVE DRAINAGE MAY BE ACCOMPLISHED BY SWALES, DRYWELLS, FRENCH DRAINS, LATERALS TO THE STREET, LATERALS BEHIND THE CURB OR WITHIN A PUBLIC UTILITY EASEMENT, AN APPROVED SYSTEM, IN THE SIDE OR REAR SETBACK, OR SOME OTHER METHOD ACCEPTABLE TO THE RESPONSIBLE OFFICIAL.

NO.	REVISIONS	DATE	BY

DWG: D27.DWG

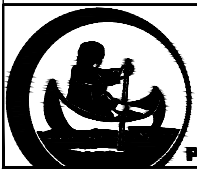

Department of Public Works
CLARK COUNTY WASHINGTON
 proud past, promising future

LOW POINT FOOTING DRAIN
 (PREFERRED METHOD)

[Signature]
 APPROVED
 COUNTY ENGINEER

01/07/16
 DATE

STANDARD
D27
 DETAIL
 DESIGNED
 DRAWN
 DATE 01/30/15