

SPEED BUMPS (14' AND 22' WIDE)

SPEED BUMP (14' WIDE)

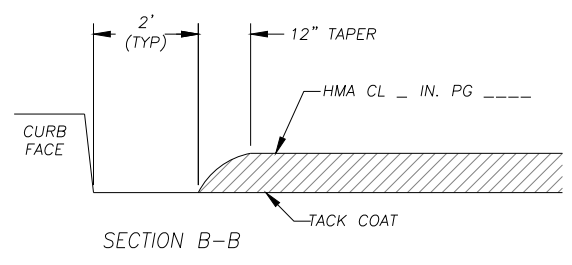

SPEED BUMP (22' WIDE)

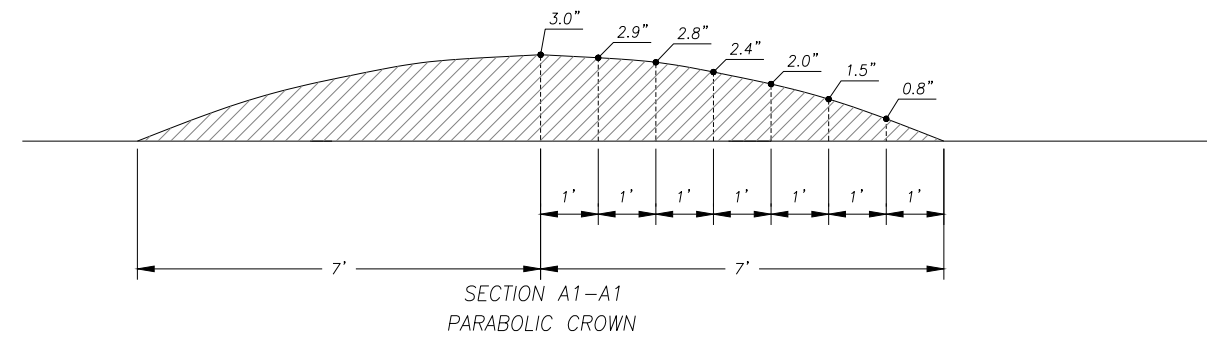
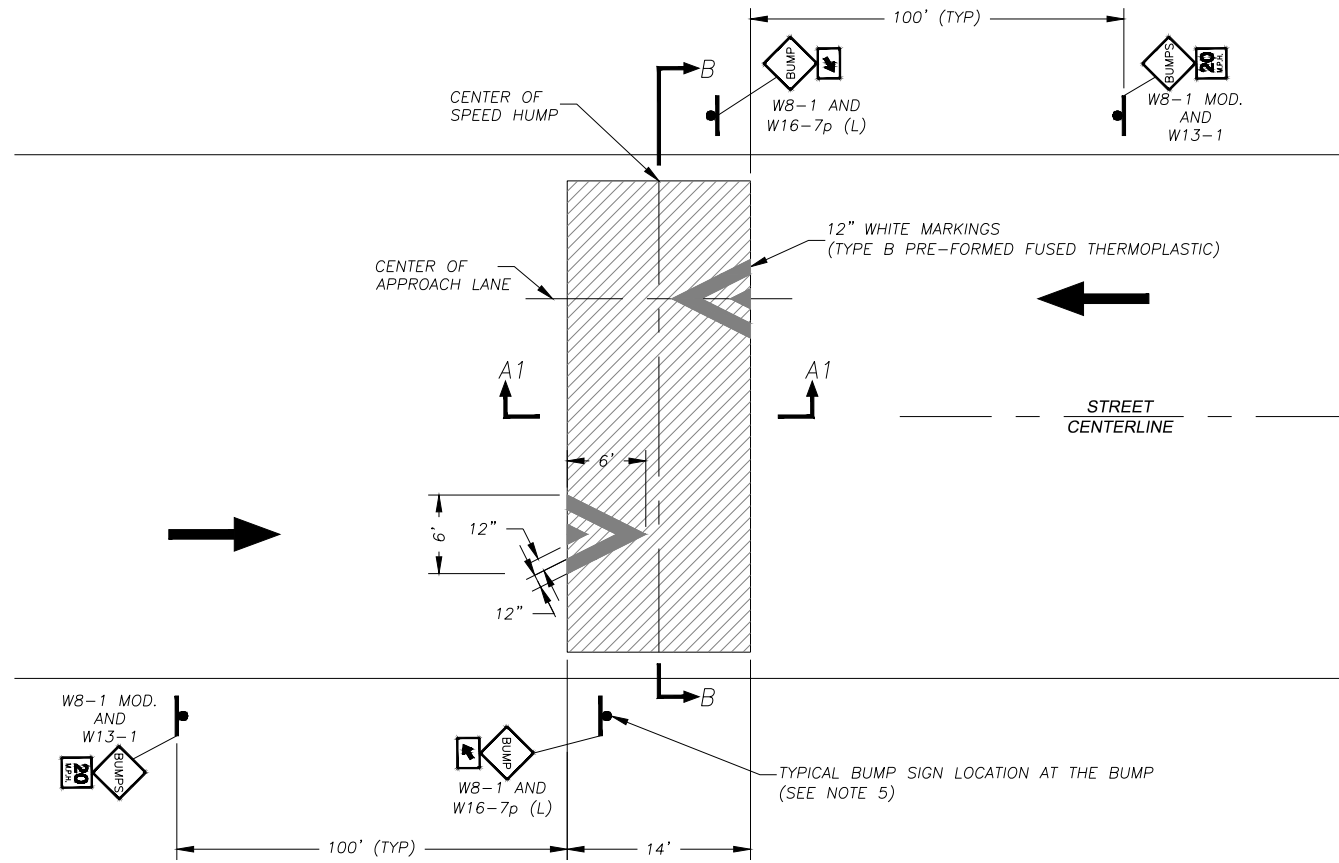
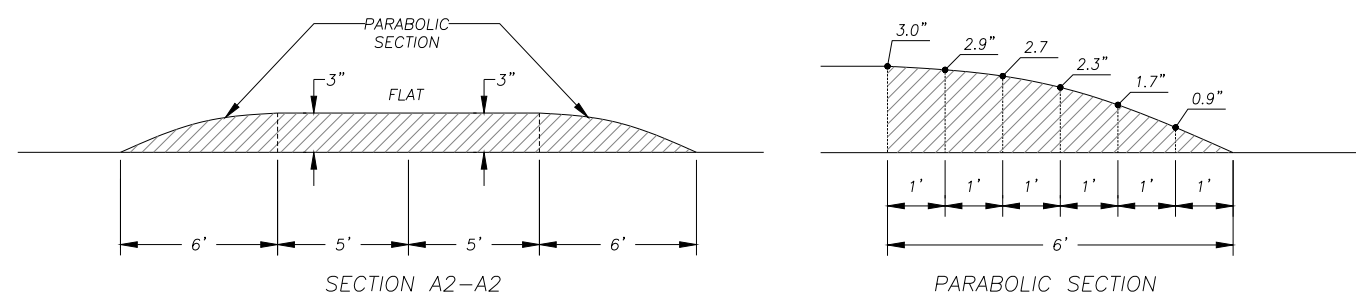
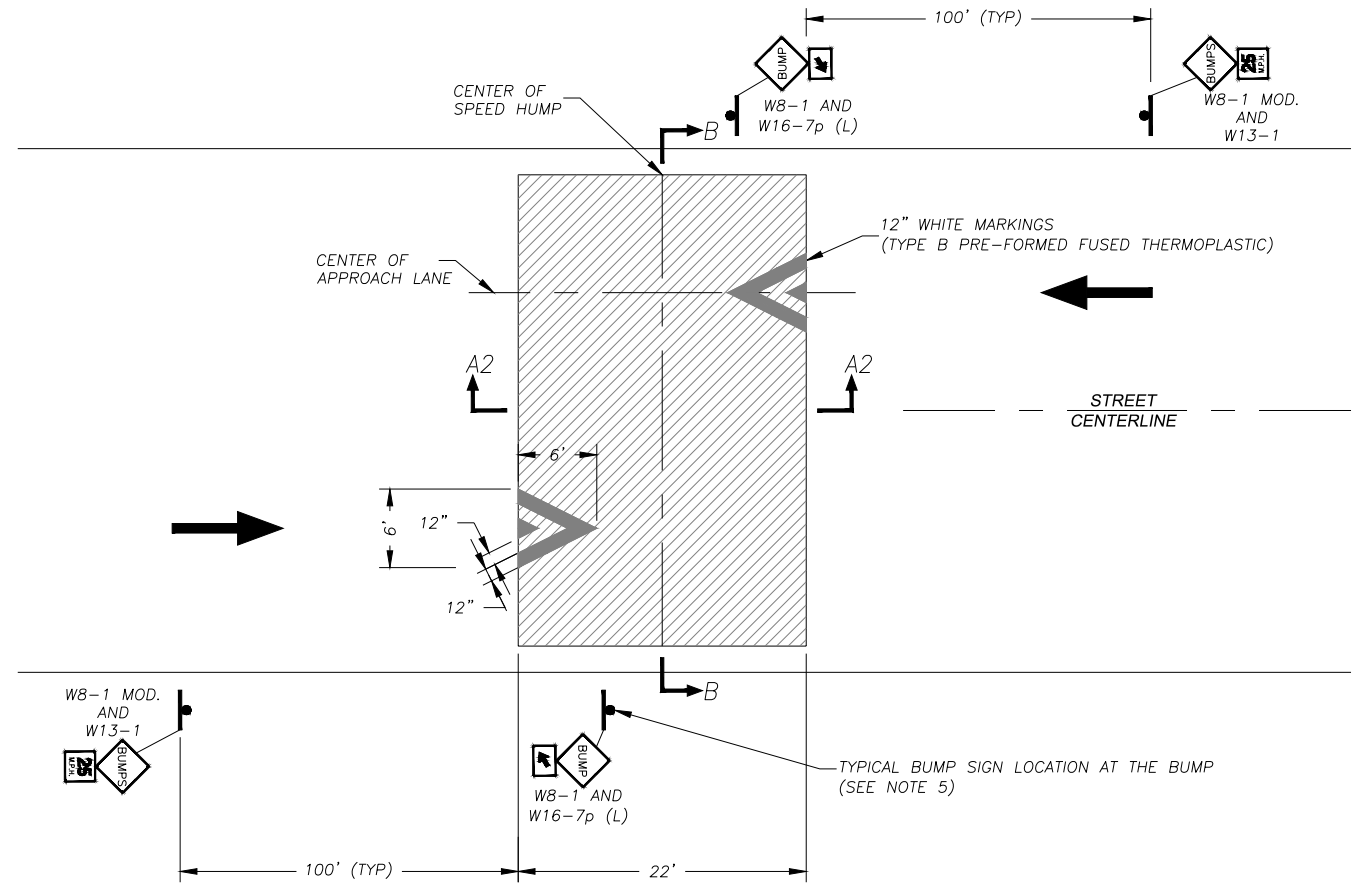

NOTES:

1. A WARNING SIGN (W8-1) WITH ADVISORY SPEED SHALL BE INSTALLED APPROXIMATELY ONE HUNDRED FEET PRIOR TO THE FIRST VERTICAL DEFLECTION IN THE CORRIDOR. THE WARNING SIGN MAY BE REPEATED AFTER A MAJOR CROSS-STREET (COLLECTOR OR ABOVE).
2. ADVANCE WARNING SIGN WOULD NOT BE NECESSARY PRIOR TO SUBSEQUENT SPEED BUMPS IN THE CORRIDOR.
3. FOR A SERIES OF SPEED BUMPS IN A CORRIDOR, WARNING SIGN W8-1 (BUMP) WITH AN ADVISORY SPEED PLAQUE W13-1P AND A SUPPLEMENTAL PLAQUE W16-4P BELOW THE ADVISORY PLAQUE, ADVISING THE DRIVERS ON THE LIMITS OF THE TRAFFIC CALMING E.G.; "NEXT 1/2 MILE", (W7-3AP) MAY BE INSTALLED APPROXIMATELY 100 FEET BEFORE THE FIRST BUMP IN THE SERIES.
4. TYPICAL SIGN SIZES:
 - W7-3ap NEXT XX MILES - 24" X 18"
 - W8-1 BUMP - 30" X 30"
 - W8-1 MOD. BUMPS - 30" X 30"
 - W13-1p ADVISORY SPEED - 18" X 18"
 - W16-4p NEXT XX FEET - 30" X 24"
 - W16-7p (L) DOWNWARD ARROW - 24" X 12"
5. THE W8-1/W16-7p(L) SIGN ASSEMBLY SHOULD BE PLACED OUTSIDE OF DRIVEWAYS. WHERE POSSIBLE, THE SIGN ASSEMBLY SHOULD BE SHIFTED TOWARDS PROPERTY LINES. WHERE POSSIBLE, THE SIGN ASSEMBLY SHOULD BE SHIFTED TO BE OUTSIDE OF THE DIRECT VIEW OF ANY PICTURE WINDOWS OF ADJACENT HOMES. THE W8-1/W16-7p(L) SIGN ASSEMBLY SHOULD BE INSTALLED BETWEEN THE LEADING EDGE OF THE BUMP AND THE CENTER OF THE BUMP. AN ACCEPTABLE ALTERNATIVE IS TO LOCATE THE SIGN ASSEMBLY WITHIN 10 FEET OF THE LEADING EDGE OF THE BUMP. ANY OTHER LOCATION SHOULD BE REVIEWED WITH THE ENGINEER.

REV. NO.	DATE	BY	APPR

DWG:

Department of
Public Works
CLARK COUNTY
WASHINGTON
proud past, promising future

SPEED BUMPS
(14' AND 22' WIDE)

APPROVED

COUNTY ENGINEER

07/17/19
DATE

T22.0	STANDARD
DESIGNED	DRAWN
DRAWN	DATE