

SEE STANDARD DETAIL F1 FOR CONSTRUCTION NOTES D1-D11. ALL NOTES APPLY UNLESS OTHERWISE NOTED.

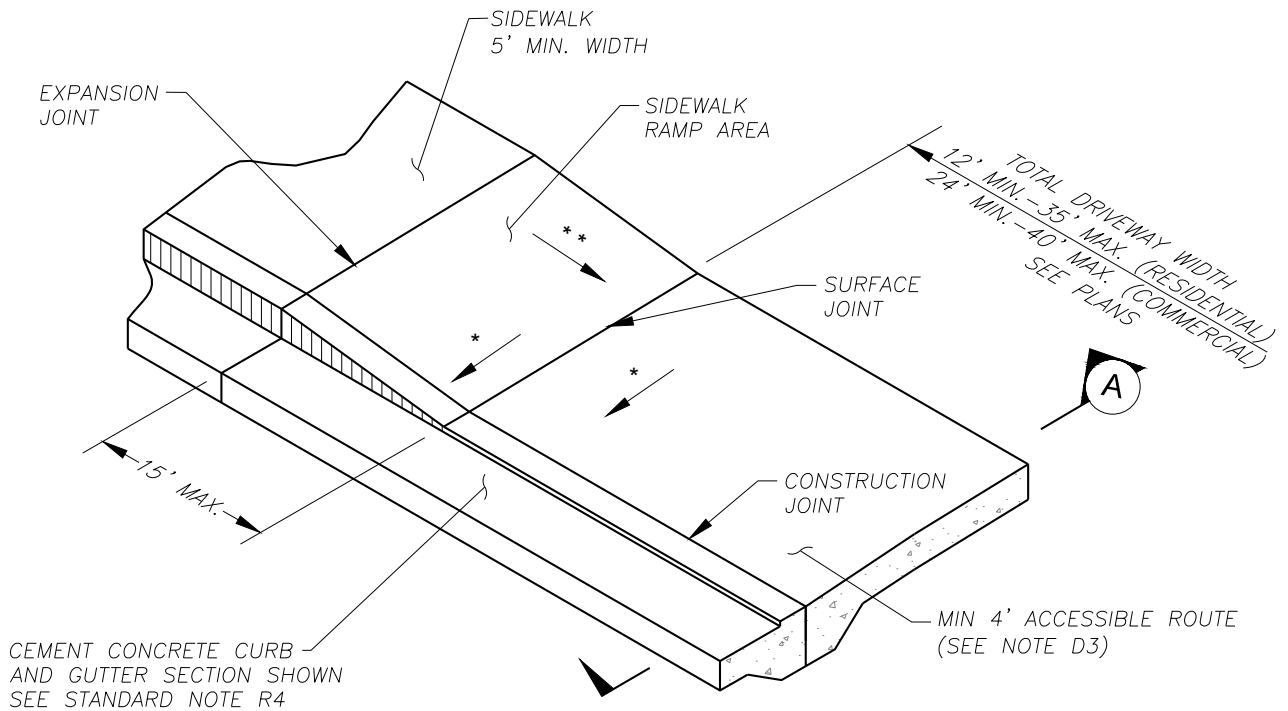

HALF ISOMETRIC

- * 1.5% OR FLATTER RECOMMENDED FOR DESIGN/FORMWORK (2% MAX)
- ** 7.5% OR FLATTER RECOMMENDED FOR DESIGN/FORMWORK (8.3% MAX)

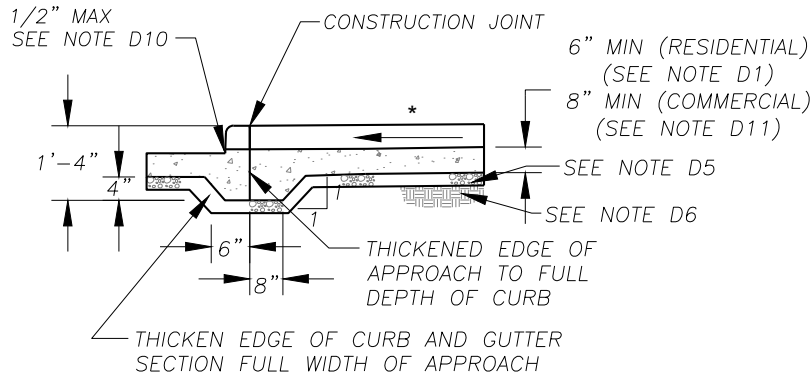

SECTION A-A

DWG: F15.DWG

NO.	REVISIONS	DATE	BY
1	REVISE GRADES	5-1-17	BK



Department of Public Works
CLARK COUNTY
 WASHINGTON
 proud past, promising future

CEMENT CONCRETE APPROACH
 TYPE 2 - ATTACHED SIDEWALK

APPROVED
[Signature]
 COUNTY ENGINEER

01/26/16
 DATE

STANDARD
F15
 DETAIL
 DESIGNED
 DRAWN
 DATE 01/26/16