

BMP T5.10A: Downspout Full Infiltration - Drywells

Purpose and Description

Downspout Full Infiltration Drywells are designed to infiltrate runoff from roof downspout drains and cannot be used to directly infiltrate runoff from pollutant-generating surfaces. These facilities can be pre-manufactured structures, or they can be simply holes in the ground filled with rock, as shown in [Figure 2.1](#). Alternatives to rock-filled drywells, such as preformed chambers, are acceptable if equivalent storage volume is provided.

Cross Reference Guide

Soils Assessment	Book 1, Section 2.3
Meets Minimum Requirements	#5
Related BMPs	None
T5.10a Selection Criteria	Book 1, Sections 2.2 and 2.5.1
Maintenance	Book 4

Applications, Limitations and Setbacks

Geotechnical analysis is an important first step to determining the feasibility of using downspout full infiltration. The required site analysis includes an initial assessment of the type of site soils, and the infiltration potential. See [Section 2.3 in Book 1](#) for guidance regarding required site soils analysis.

Roof downspout drywells are deemed feasible without infiltration testing when a qualified professional determines that USDA textural classes consisting of coarse sand to medium sand, loam, or cobbles and gravels are present in the infiltration zone. If other soils are present in the infiltration zone consider a rain garden or bioretention facility instead.

Items that make roof downspout drywells infeasible include:

- Less than three feet of permeable soil exists from the proposed finished ground elevation above the drywell to the seasonal high groundwater table.
- Less than one foot of clearance exists between the proposed bottom of the drywell and the seasonal high groundwater table.
- The downspout full infiltration system cannot meet the setbacks specified below.
- The downspout full infiltration system cannot meet the design criteria specified below.

Setbacks

- 100 feet from closed or active landfills.
- 10 feet from any sewage disposal drain field, including reserve areas and grey water reuse systems.
- 100 feet up gradient from any septic system unless site topography clearly prohibits subsurface flows from intersecting the drain field.
- 10 feet from an underground storage tank and its connecting pipes that is used to store petroleum products, chemical, or liquid hazardous wastes in which 10% or more of the storage volume of the tank and connecting pipes is beneath the ground.
- 10 feet from any structure, property line, or sensitive area (except slopes over 40%). However, if the roof downspout infiltration system is a common system shared by two or more adjacent residential lots and contained within an easement for maintenance given to owners of all residential properties draining to the system, then the setback from the property line(s) shared by the adjacent lots may be waived.

Design Criteria

- Drywell bottoms must be a minimum of 1 foot above seasonal high groundwater level or impermeable soil layers
- Drywells shall contain a minimum volume of gravel:
 - If located in coarse sands and cobbles (defined as a particle size of 2mm or greater in accordance with ASTM D422-63 particle size analysis), at least 60 cubic feet of gravel per 1,000 square feet of impervious surface served.
 - If located in medium sands (defined as 0.5 mm to 2 mm in accordance with ASTM D422-63 particle size analysis), at least 90 cubic feet of gravel per 1,000 square feet of impervious surface served.
- Drywells shall be at least 4 feet in diameter and deep enough to contain the gravel amounts specified above for the soil type and impervious surfaced served.
- Choking stone or filter fabric (geotextile) shall be placed on top of the drain rock and filter fabric shall be placed on drywell sides prior to backfilling. Filter fabric shall not be placed on the bottom.
- Spacing between drywells shall be a minimum of 10 feet.
- A geotechnical analysis and report is required on slopes over 15% or if located within 200 feet of the top of slope steeper than 40%, or in a landslide hazard area.

Runoff Modeling Representation

- If roof runoff is infiltrated according to the requirements of this section, the roof area may be removed from the project area used for sizing stormwater facilities.

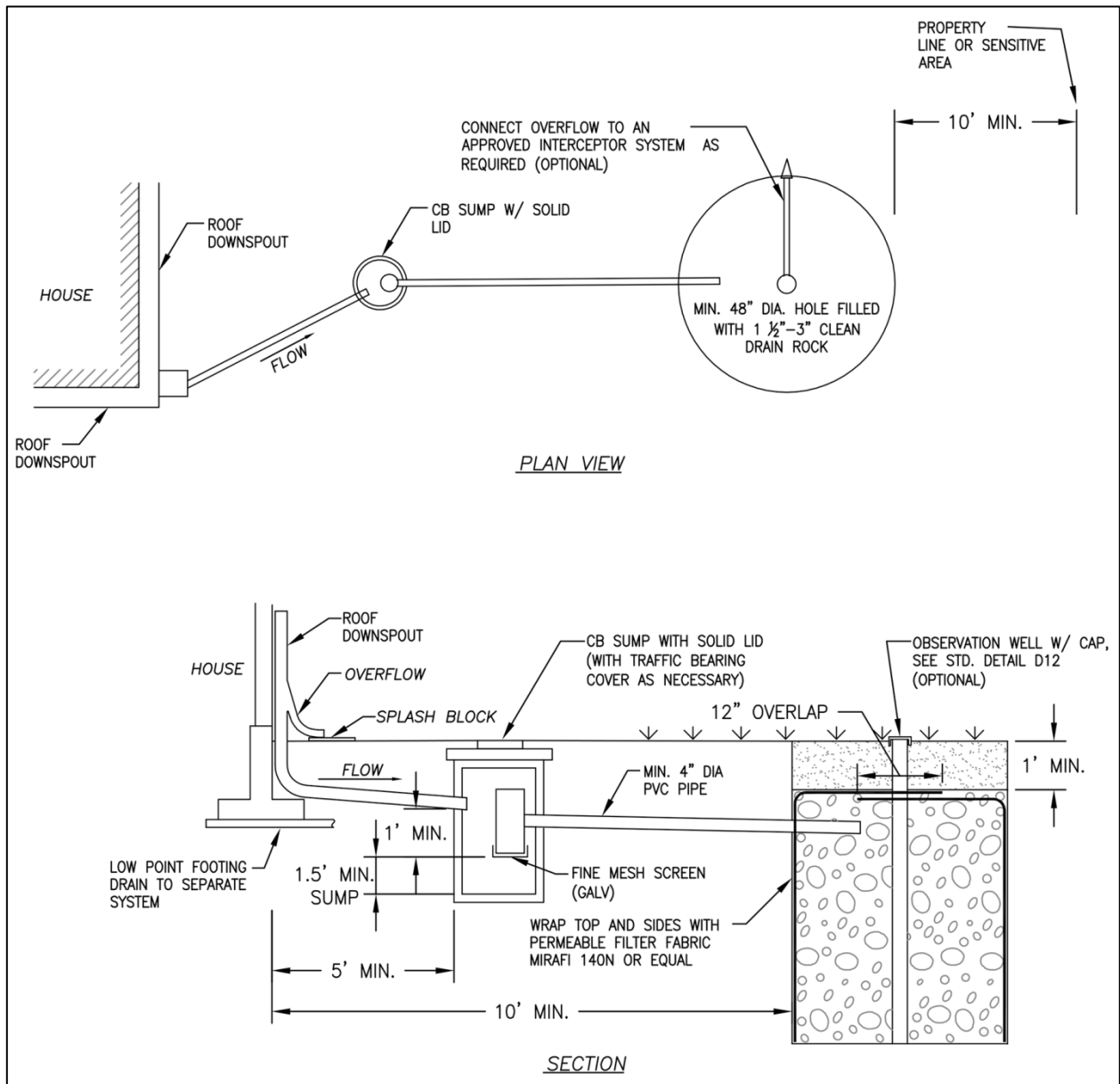

Figure 2.1: Typical Downspout Infiltration Drywell

(Source: modified from Clark County)